

ADVANTAGE BASE C180

LASER FUME EXTRACTION SYSTEMS

For use with the GCC C180 Laser Engraver.

The Advantage Base C180 has been designed specifically for the new GCC C180 laser engraver. The dimensions of the unit allow the C180 to fit perfectly onto the extractor, effectively doubling it up as a work station. The distinctive blue finish has been matched with the blue of the laser to give a stylish installation. The unit is also offered with an onboard air compressor to provide the laser its air assist requirements. All units come complete with extraction hose kit and compressor link up on compressor models.

- Noise Level less than 55dBa
- Filters with long life and low replacement costs.
- Stylish colour match with C180
- On Board compressor versions
- Comes complete with extraction hose kit
- Easi Glide Filter location mechanism



PART NUMBERS

Model		Part Number	VOC Monitoring	Compressor
AD Base C180	230v	L2142A	A2003	A2007
	115v	L2141A		

Other Hose Kits are available. All of the above units are fitted with our standard filter combinations. For specific applications please call us for details.

REPLACEMENT FILTERS*

Model	Pre Filter	HEPA Filter	Gas Filter 50L
AD Base C180	A1030077	A1030078	A1030061

* Other Filters are available. Please call us for details.

TECHNICAL DATA

Model	AD Base C180	
	EC	US
Dimensions (h x w x d)	795 x 720 x 675mm	31.3 x 28.3 x 26.6"
Weight	86kg	190lbs
Cabinet Construction	Powder coated mild steel	Powder coated mild steel
Blower	135w	135w
Electronics	230v 50/60Hz Full load current: 2.7 amps	115v 50/60Hz Full load current: 1.2 amps

FILTER SPECIFICATIONS

	Pre Filter	HEPA Filter	Gas Filter
Part Number	A1030077	A1030078	A1030061
Filter Media	Polyester	Glass Fibre	Impregnated Carbon 25kg
Surface Area	2.2m ²	7.5m ²	N/A
Construction	8 Pocket	Maxi Pleat	Granules
Housing	Polyester	Mild Steel	Mild Steel
Efficiency	EU6 (85% @ 0.8 microns)	H13 (99.997% @ 0.3 microns)	N/A

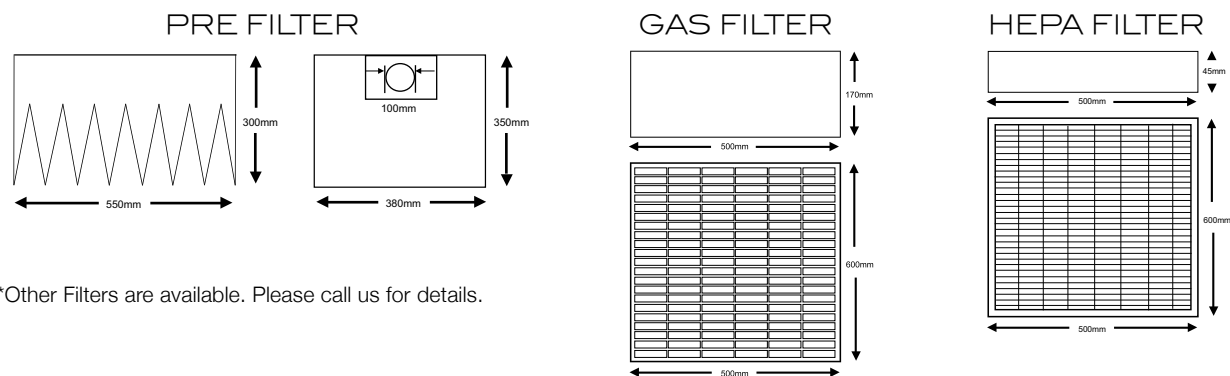

*Other Filters are available. Please call us for details.

TECHNICAL SPECIFICATION

- Unit/Filter Condition Display
- On/Off Switch
- Filter Housing Cam Latch
- Extracted Air Outlet
- Hose Inlet Connection 100mm
- Signal/ Interface Cable to Laser
- Power Cable
- Motor Cooling Inlet
- Motor Cooling Outlet
- Compressed Air Outlet
- Castors
- Door Hinges
- Machine Identification

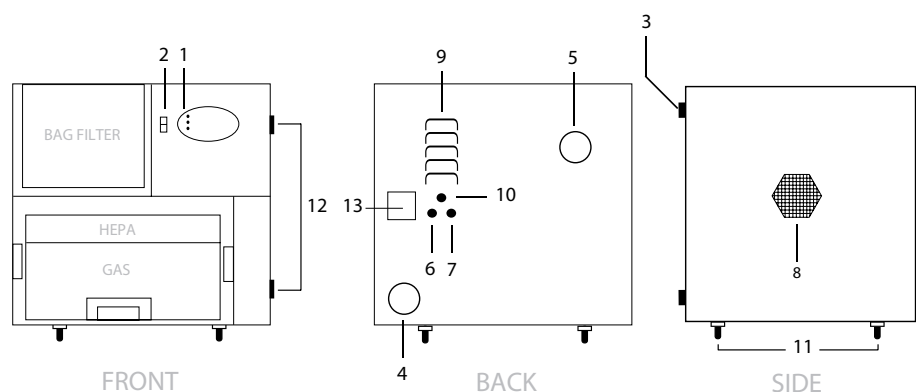

HEAD OFFICE

21-22 BALENA CLOSE
CREEKMOOR
INDUSTRIAL ESTATE
POOLE, DORSET, UK
BH17 7DX

T. +44 (0) 1202 699 444
F. +44 (0) 1202 699 446
E. SALES@BOFA.CO.UK
W. WWW.BOFA.CO.UK



USA OFFICE

BOFA AMERICAS
1395 SOUTH HACKMAN STREET
STAUNTON,
ILLINOIS, USA
62088

T. (618)-635-4465
F. (618)-635-2695
E. SALES@BOFAAMERICAS.COM
W. WWW.BOFAAMERICAS.COM

ADVANTAGE BASE C180



AUTHORISED AGENT