

## DP50F

### Basic system 48 W

State-of-the-art components for excellent beam quality and compactness at the same time, this was the main focus for the development of the new laser DP50F. The pulsed fiber laser with its high power reserves expands the existing laser series in the upper power range, thereby reducing the cycle times significantly. Because of the small dimensions of the laser head this system is ideally suited to be integrated into production lines.

Annealing marking, deep marking and GSM card marking are a part of the broad application range.



#### Advantages

- Long working life of the laser diodes means little servicing
- Small compact air-cooled lasers
- Excellent laser beam quality with small beam diameter
- Output power 48 W
- Single-phase 230 V mains connection

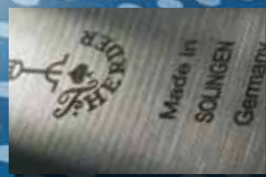

# DP50F

## Basic system 48 W

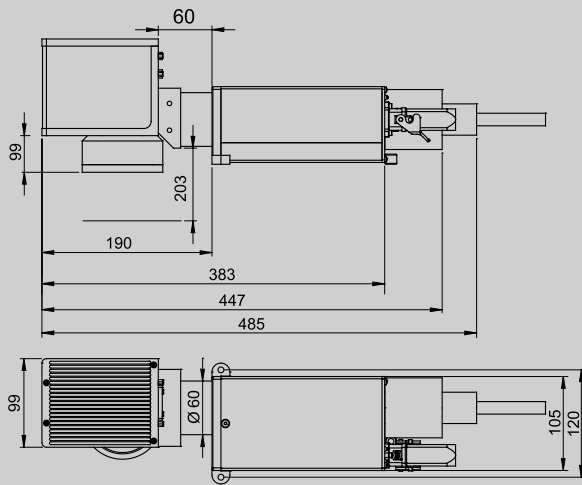

Laser head with standard scan head and lens

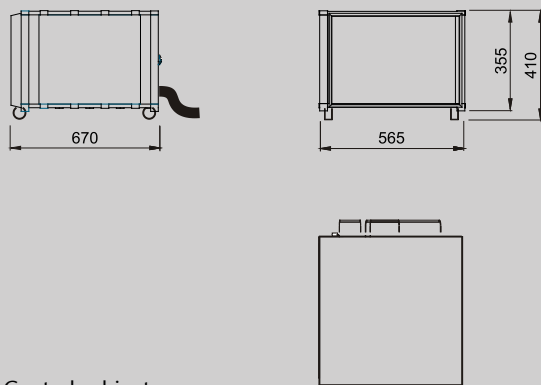

Control cabinet

### System

Marking field	110 x 110 mm <sup>2</sup> (f=160 mm)
Marking speed	up to 6000 mm/s up to 600 characters/s
Line width	typically 50 µm

### Laser

Laser type	Pulsed Yb Fiber Laser, 1055 -1070 nm, diode pumped
Power (QS) typically	48 W
Power stability	+/- 2.5 % (QS)
Output modes	Pulsed operation (QS, 50 - 100 kHz)
Pulse energy	0.90 mJ (50 kHz)
Pulse width	110 ns (50 kHz)

### Control

PC	CompactPCI-PC
Operating system	MS Windows XP
Laser control	FOBAGRAF with Import functions of plt/dwg/dxf/ai/jpg/tif/pcx/bmp ...
Interfaces	serial, digital I/O, Ethernet, USB, Profibus

### Installation

Electrical	L/N/PE, AC 100 - 138 V, 187 - 240 V, 50/60 Hz
Power consumption	maximal 700 W
Cooling	Air
Temperature	15 - 35 °C (50 % f) 15 - 32 °C (100 % f)
Humidity	90 % (up to max. 20 °C) 40 % (up to max. 35 °C) non-condensing
Weight	Laser head approx. 5 kg <sup>1)</sup> Control cabinet approx. 45 kg <sup>2)</sup>
Degree of protection	Laser head IP54 Control cabinet IP43
Safety	Class IV Laser

### Options

Pointer	Adjustment aid
High-speed scan head	
Changeable lens	

<sup>1)</sup> without F-Theta lens

<sup>2)</sup> with OEM-Components

# FOBA®

Laser Marking + Engraving

ALLTEC GmbH  
Altenaer Straße 170a  
58513 Lüdenscheid  
GERMANY

Phone +49 2351 996-0  
Fax +49 2351 996-234

info@fobalaser.com  
www.foba.de | www.fobalaser.com

