



OMNIBEAM

Advanced Laser Machining Center



Features

- High power and low operating cost sealed CO₂ laser
- Auto-Focus system for fast setup
- Large format cutting area
- Gull wing, dual access doors with removable pallet, front and rear pass through

Options

- Machine vision
- Auto-pallet loading
- Bar Code job load

Flexible, High Speed Precision

The OMNIBEAM is the compact and powerful answer for prototype to high volume manufacturing applications.

The OMNIBEAM is the most versatile choice for precision cutting a wide range of materials, non-metals up to 25 mm and metals up to 2 mm. Simple user interface and job loading software simplifies work set up and increases productivity.

Mechanical Specifications

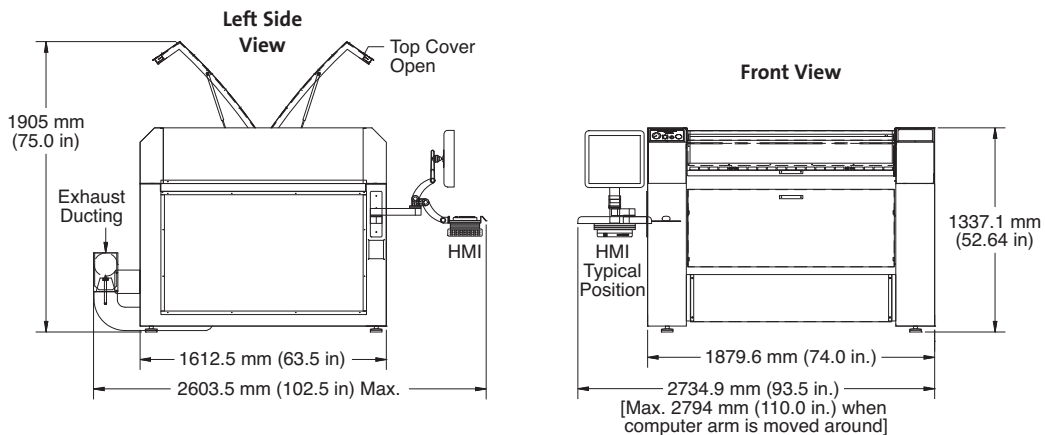

Superior Reliability & Performance

OMNIBEAM™

Advanced Laser Machining Center

System Specifications

	OMNIBEAM 150	OMNIBEAM 250	OMNIBEAM 400	OMNIBEAM 500
Laser Power/Peak Power (W)	150/375 ¹	250/750 ¹	400/1000 ¹	500/1500 ¹
Dimensions (L x W x H)	1630 x 1990 x 1320 mm (64.2 x 78.4 x 52.0 in.)			
Weight	725 kg (1600 lbs.)			
Cutting Height	1020 mm (40.0 in.)			
Working Range	x = 1220 mm (48.0 in.) y = 1220 mm (48.0 in.) z = 300 mm (12.0 in.)			
Maximum Speed	50,800 mm (2000 in.)/min. cutting 91,500 mm (3600 in.)/min. rapid positioning 91,500 mm (3600 in.)/min. raster engraving			
Positioning	Linear encoders with 2 micron resolution in closed loop with brushless servo motors			
Accuracy	25 µm (0.001 in.) positioning accuracy ² 5 µm (0.0002 in.) repeatability			
Contouring	Full look-ahead contouring capability			
Materials	Metal, Plastics, Wood, Paper, Composites, Fabric, Rubber			
Software Interface	LaserLink program including: Windows 7 support G-code support AI, DXF, HPGL, DWG, Gerber, JPG, BMP, TIF file import Full geometry editing Editable database of laser parameters Job estimator software Job management software			
Cutting Pallets	Removable pallet system with front and rear pass-through Honeycomb work support			
Laser Power Control	Digital laser power control Power proportional to velocity			
Focusing	Auto-focus			
Exhaust/Vacuum Bed	Vacuum material hold-down plenum External high pressure exhaust blower required			
Cooling	External chiller			
PC/File Server	Windows/Ethernet			
Power ³ (VAC)	208 to 240, 47 to 63 Hz, three-phase, 20A	30A	50A	50A
Safety	Safety interlocks on all covers and enclosures Class I system (Complies with 21 CFR Chapter 1, Subchapter J)			
User Controls	Touch Screen control panel Jog, Bed height controls Home, Park, Load buttons Exhaust, gas assist controls Editing of laser settings Networked HMI workstation Auto restart			

¹ These specifications are applicable as of September 2009 and are subject to change without notice.

² Accuracy quoted is under controlled conditions. Accuracy may vary depending on conditions in customer's facility.

³ The current required is dependent on the laser used.

Coherent follows a policy of continuous product improvement. Specifications are subject to change without notice.

Coherent's scientific and industrial lasers are certified to comply with the Federal Regulations (21 CFR Subchapter J) as administered by the Center for Devices and Radiological Health on all systems ordered for shipment after August 2, 1976.

Coherent offers a limited warranty for all OMNIBEAM laser machining centers. For full details of this warranty coverage, please refer to the Service section at www.Coherent.com or contact your local Sales or Service Representative.



www.Coherent.com

Coherent, Inc.
5100 Patrick Henry Drive
Santa Clara, CA 95054
phone (800) 527-3786
(408) 764-4983
fax (408) 764-4646
e-mail tech.sales@Coherent.com

Benelux +31 (30) 280 6060
China +86 (10) 8215 3600
France +33 (0)1 8038 1000
Germany +49 (6071) 968 333
Italy +39 (02) 31 03 951
Japan +81 (3) 5635 8700
Korea +82 (2) 460 7900
UK +44 (1353) 658 833